



STRAPPING MACHINE

MODEL RANGE: AMPAG SPEED TR / AMPAG SPEED TR-P



MODEL RANGE: AMPAG SPEED TR HIGH-SPEED TECHNOLOGY

The fully-automatic high-speed strapping machine is suitable for integration in your fully-automatic packing lines. Up to 40 packages can be strapped per minute with a capacity of up to 65 strapping cycles per minute.

In detail the Ampag Speed TR is characterised by the following innovative features:

- DC drive technology with wear-free direct drives
- Sensor-controlled welding system
- Extremely high operating comfort due to clear text display
- Strap tension is adjustable per potentiometer
- Automatic threading system
- Automatic strap loop discharge
- Tool-free access to the components on the strap path on the strapping head
- Strap end monitoring with strap discharge
- Strap change with fast change system
- Conveyor speed infinitely adjustable
- Soft strapping

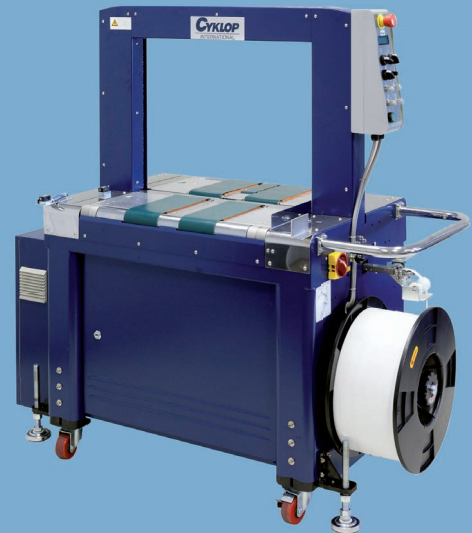

Operating Panel with LCS Display

- Several languages can be installed
- Easy and clear operation
- Extreme operating comfort due to clear text display
- Setting and visualisation of strapping parameters



High Quality Strap Guide

- Particularly low wear
- Integrated brush guide

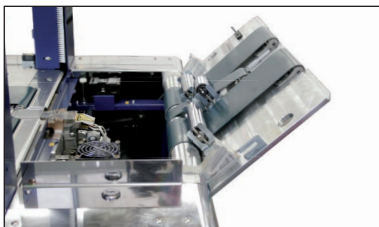

Table Top with Transport System, open on both sides

- Can be opened without tools
- Easy accessibility
- Adjustable transport speed



Machine manoeuvrable

- Four castors two thereof with brakes
- Adjustable from 800 – 900 mm or 750 – 900 mm (option)
- Four feet

MODEL RANGE: AMPAG SPEED TR IT'S THE DETAILS THAT COUNT!

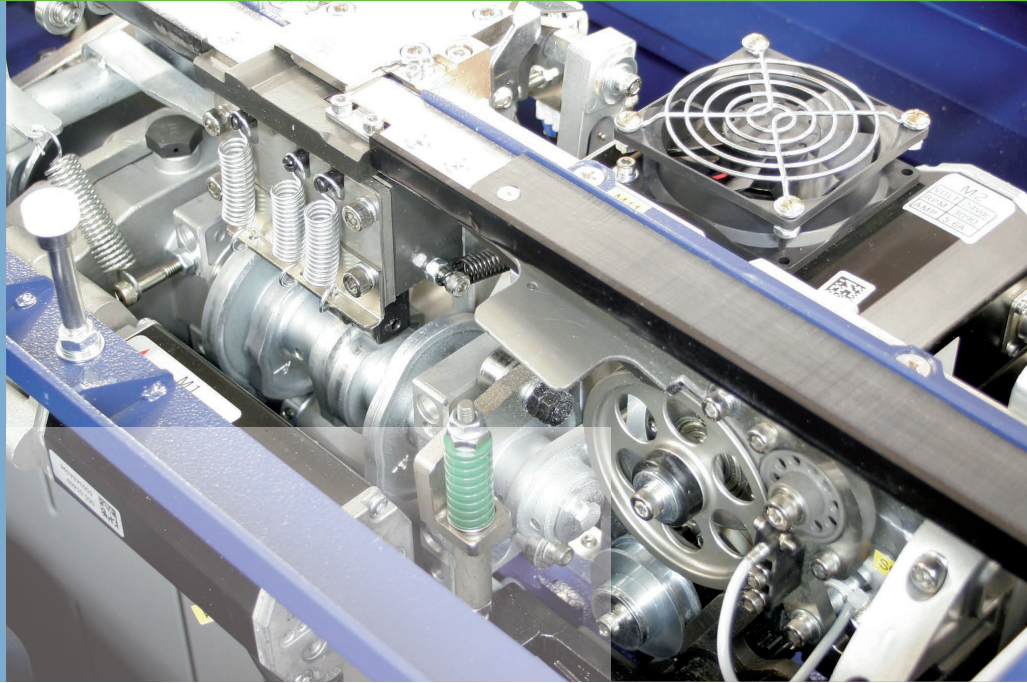

Direct Drive Concept

- Energy-saving, brushless DC technology
- Made in Germany

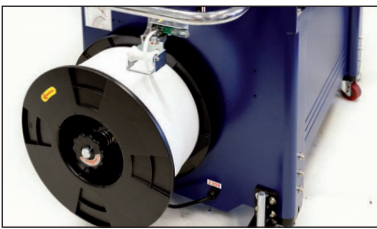

Ergonomic Spool Change

- Operator-friendly
- Strap spool with fast change system
- Automatic strap threading system
- Strap end monitoring with strap discharge

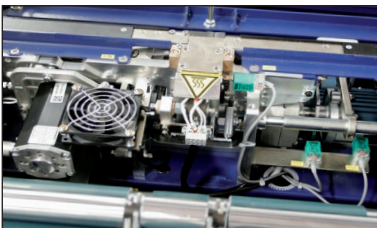

Strapping Head

- No V-belts, no clutches
- Minimum maintenance
- Minimum noise emission

Options

Siemens control

Strap spool monitoring with 3 coloured signal lights

Additional foot switch with cable (1.5 m)

Extended conveyor belts (entry and exit – 200 mm each)

Stainless steel (chassis)

Ampag Speed with pressure bar: TR-P

Model range: Ampag Speed TR

Technical Data:

Model	Ampag Speed TR	Ampag Speed TR-P
Capacity	up to 65 cycles/min. up to 40 packages/min. frame size W 650 x H 500	up to 65 cycles/min. up to 36 packages/min. frame size W 650 x H 500 mm
Strap size	Strap width: 5 mm / 9 mm / 12 mm Strap thickness: 0.35 mm – 0.65 mm	
Strap spool core	200 mm	
Strap tension	5 mm or 9 mm = 1 up to 32 kg / 12 mm = 1 up to 45 kg	
Table height	800 - 900 mm (750 - 900 mm)*	
Machine weight	225 kg	250 kg
Package	Weight max. 35 kg Min. 130 x 120 x 10 mm (L x W x H) Max. 600 x 450 mm (W x H) (w. Frame size W 650 x H 500)	
Transport speed	10 - 60 m/min	
Operating voltage	220V/230V (50Hz) 1PH / 380V/400V (50Hz) 3PH	
Temperature	5 - 40 °C	
Operating pressure	6 bar	
Air consumption	7.5 NI/cycle	

Dimensions:

(e. g. frame size 650 x 500)

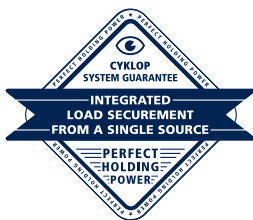
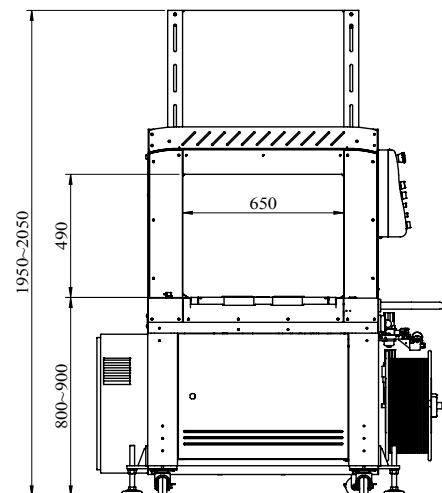
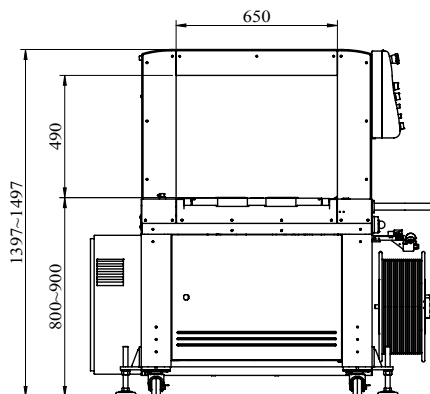
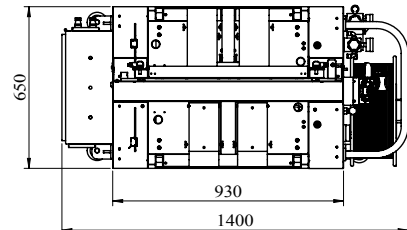
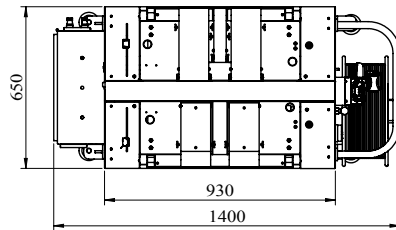

(*Option)

WWW.CYKLOP.NL
+31 (0) 38 4675 800

CYKLOP Nederland BV
Benjamin Franklinstraat 5
8013 NC ZWOLLE
The Netherlands
info@cyklop.nl

CYKLOP
INTERNATIONAL

THE
STRAPPING
COMPANY

100 YEARS
1912/2012